



Dell PowerConnect W-AP130 Series Access Point Installation Guide

The Dell W-AP130 Series of wireless access points support the IEEE 802.11n standard for high-performance WLAN. These access points use MIMO (Multiple-in, Multiple-out) technology and support existing 802.11a/b/g/n wireless services. The W-AP130 Series access points work only in conjunction with a Dell Controller.

The Dell W-AP130 Series access points provide the following capabilities:

- Wireless transceiver
- Protocol-independent networking functionality
- IEEE 802.11a/b/g/n operation as a wireless access point
- IEEE 802.11a/b/g/n operation as a wireless air monitor
- Compatibility with IEEE 802.3at PoE
- Central management configuration and upgrades through a Dell Controller

Minimum Software Requirements

The W-AP130 Series access point requires ArubaOS 6.1.1 or later.

Package Contents

- W-AP130 Series access point
- Installation guide (this document)
- 9/16" Ceiling Rail Adapter
- 15/16" Ceiling Rail Adapter



NOTE: Inform your supplier if there are any incorrect, missing, or damaged parts. If possible, retain the carton, including the original packing materials. Use these materials to repack and return the unit to the supplier if needed.



NOTE: Additional mounting kits for use with the W-AP130 Series access points are sold separately. Contact your Dell sales representative for details.

Device Overview

Figure 1 W-AP130 Series Access Points (W-AP134 Shown)

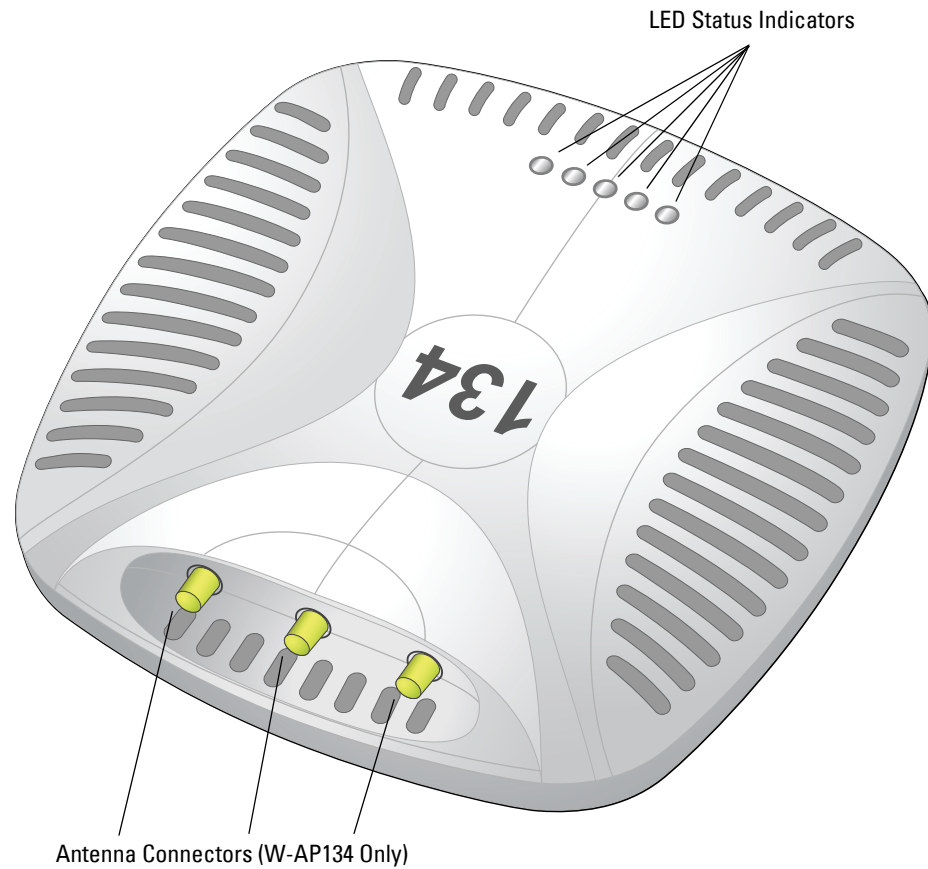

AP-134_003

LEDs

The W-AP130 Series access point is equipped with five LEDs that indicate the status of various components of the device.

- PWR: Indicates the whether or not the W-AP130 Series is powered on and its status.
- ENET 0: Indicates the status and activity of Ethernet port 0
- ENET 1: Indicates the status and activity of Ethernet port 1
- 11b/g/n: Indicates the status of the 2.4 GHz radio
- 11a/n: Indicates the status of the 5.0 GHz radio

For more information about the LEDs and their behavior, see [Table 3 on page 9](#).

External Antenna Connectors

The W-AP134 is designed for use with external antennas. The W-AP135 is equipped with internal antennas.

Figure 2 W-AP130 Series Rear

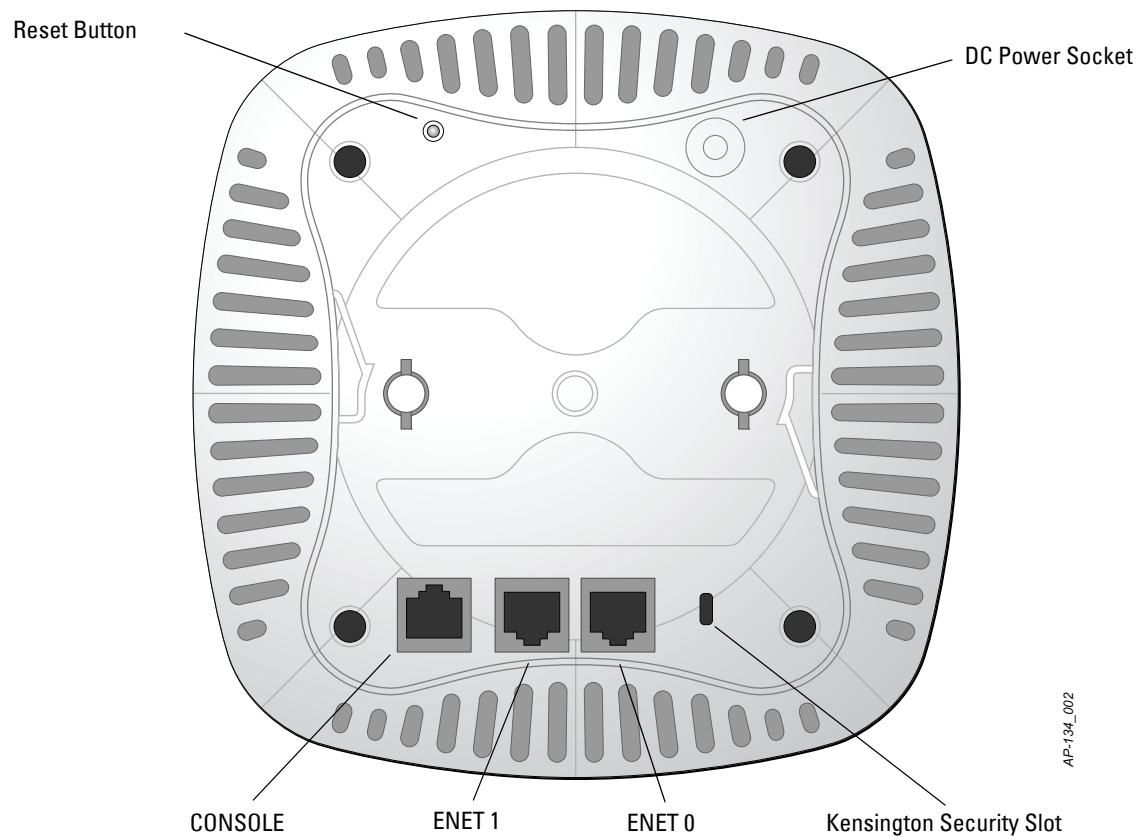

Console Port

Use the console port to connect to a terminal for direct local management.

Ethernet Ports

W-AP130 Series is equipped with two 10/100/1000Base-T (RJ-45) auto-sensing, MDI/MDX wired-network connectivity port. These ports support IEEE 802.3at Power over Ethernet (PoE) compliance, accepting 56VDC as a standard defined Powered Device (PD) from a Power Sourcing Equipment (PSE) such as a PoE midspan injector, or network infrastructure that supports PoE.

DC Power Socket

If PoE is not available, an optional Dell AP AC-DC adapter kit (sold separately) can be used to power the W-AP130 Series.

Reset Button

The reset button can be used to return the AP to factory default settings. To reset the AP:

1. Power off the AP.
2. Press and hold the reset button using a small, narrow object, such as a paperclip.
3. Power-on the AP without releasing the reset button. The power LED will flash within 5 seconds.
4. Release the reset button.

The power LED will flash again within 15 seconds indicating that the reset is completed. The AP will now continue to boot with the factory default settings.

Kensington Lock Slot

The W-AP130 Series is equipped with a Kensington security slot for additional security.

Before You Begin



CAUTION: FCC Statement: Improper termination of access points installed in the United States configured to non-US model controllers will be in violation of the FCC grant of equipment authorization. Any such willful or intentional violation may result in a requirement by the FCC for immediate termination of operation and may be subject to forfeiture (47 CFR 1.80).

CAUTION: EU Statement:

Lower power radio LAN product operating in 2.4 GHz and 5 GHz bands. Please refer to the Dell PowerConnect W-Series ArubaOS 6.1 User Guide for details on restrictions.



Produit réseau local radio basse puissance operant dans la bande fréquence 2.4 GHz et 5 GHz. Merci de vous référer au Dell PowerConnect W-Series ArubaOS 6.1 User Guide pour les details des restrictions.

Low Power FunkLAN Produkt, das im 2.4 GHz und im 5 GHz Band arbeitet. Weitere Informationen bezüglich Einschränkungen finden Sie im Dell PowerConnect W-Series ArubaOS 6.1 User Guide.

Apparati Radio LAN a bassa Potenza, operanti a 2.4 GHz e 5 GHz. Fare riferimento alla Dell PowerConnect W-Series ArubaOS 6.1 User Guide per avere informazioni dettagliate sulle restrizioni.

Pre-Installation Network Requirements

After WLAN planning is complete and the appropriate products and their placement have been determined, the Dell Controller(s) must be installed and initial setup performed before the Dell Access Points are deployed.

For initial setup of the Controller, refer to the *Dell PowerConnect W-Series ArubaOS 6.1 Quick Start Guide* for the software version installed on your controller.

Pre-Installation Checklist

Before installing your W-AP130 Series access point, be sure that you have the following:

- For the W-AP134: External antennas as specified in the network deployment plan
- CAT5 or better UTP cable of required length
- One of the following power sources:
 - IEEE 802.3at-compliant Power over Ethernet (PoE) source
 - The POE source can be any power source equipment (PSE) controller or midspan PSE device
 - Dell 12 VDC AP AC-DC adapter kit (sold separately)
- Dell Controller provisioned on the network:
 - Layer 2/3 network connectivity to your access point
 - One of the following network services:
 - Aruba Discovery Protocol (ADP)
 - DNS server with an “A” record
 - DHCP Server with vendor-specific options

Summary of the Setup Process



NOTE: It is important that you verify the items listed under [Pre-Installation Checklist](#) before you attempt to set up and install a W-AP130 Series AP.

Successful setup of a W-AP130 Series access point consists of five tasks, which must be performed in this order:

1. Verify pre-installation connectivity.
2. Identify the specific installation location for each AP.
3. Install each AP.
4. Verify post-installation connectivity.
5. Configure each AP.



CAUTION: Access points are radio transmission devices and as such are subject to governmental regulation. Network administrators responsible for the configuration and operation of access points must comply with local broadcast regulations. Specifically, access points must use channel assignments appropriate to the location in which the access point will be used.



NOTE: Dell, in compliance with governmental requirements, has designed the W-AP130 Series access points so that only authorized network administrators can change the settings. For more information about AP configuration, refer to the *Dell PowerConnect W-Series ArubaOS 6.1 Quick Start Guide* and the *Dell PowerConnect W-Series ArubaOS 6.1 User Guide*.

Verifying Pre-Installation Connectivity

Before you install APs in a network environment, make sure that the APs will be able to locate and connect to the Controller when powered on.

Specifically, you must verify the following conditions:

- When connected to the network, each AP is assigned a valid IP address
- APs are able to locate the Controller (Mobility Controller Discovery)

Refer to the *Dell PowerConnect W-Series ArubaOS 6.1 Quick Start Guide* for instructions on locating and connecting to the Controller.

Identifying Specific Installation Locations

You can mount the W-AP130 Series access point a ceiling rail (using the included adapter) or on a wall (using the wall mount adapter, sold separately). Use the AP placement map generated by Dell's Airwave VisualRF software application to determine the proper installation location(s). Each location should be as close as possible to the center of the intended coverage area and should be free from obstructions or obvious sources of interference. These RF absorbers/reflectors/interference sources will impact RF propagation and should have been accounted for during the planning phase and adjusted for in RF plan.

Unidentified Known RF Absorbers/Reflectors/Interference Sources

Identifying known RF absorbers, reflectors, and interference sources while in the field during the installation phase is critical. Make sure that these sources are taken into consideration when you attach an AP to its fixed location. Examples of sources that degrade RF performance include:

- Cement and brick
- Objects that contain water
- Metal

- Microwave ovens
- Wireless phones and headsets

Installing the AP



NOTE: Service to all Dell products should be performed by trained service personnel only.

Using the Ceiling Rail Adapter

The AP130 series ships with two ceiling rail adapters for 9/16" and 15/16" ceiling rails.



CAUTION: Make sure the AP fits securely on the ceiling tile rail when hanging the device from the ceiling, because poor installation could cause it to fall onto people or equipment.

1. Pull the necessary cables through a prepared hole in the ceiling tile near where the AP will be placed.
2. Place the adapter against the back of the AP with the adapter at an angle of approximately 30 degrees to the tabs (see [Figure 3](#)).
3. Twist the adapter clockwise until it snaps into place in the tabs (see [Figure 3](#)).

Figure 3 Attaching the Ceiling Rail Adapter

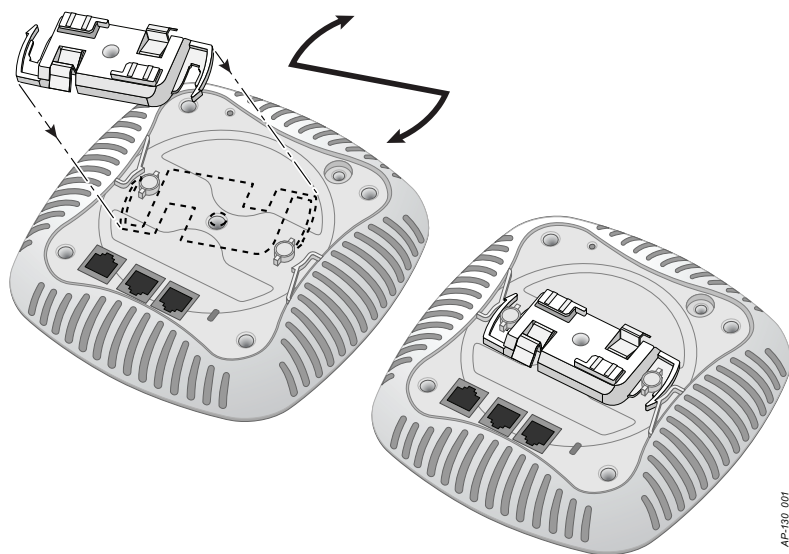

4. If necessary, connect the console cable to the console port on the back of the AP.
5. Hold the AP next to the ceiling tile rail with the ceiling tile rail mounting slots at approximately a 30-degree angle to the ceiling tile rail (see [Figure 4](#)). Make sure that any cable slack is above the ceiling tile.
6. Pushing toward the ceiling tile, rotate the AP clockwise until the device clicks into place on the ceiling tile rail.

Figure 4 Mounting the AP

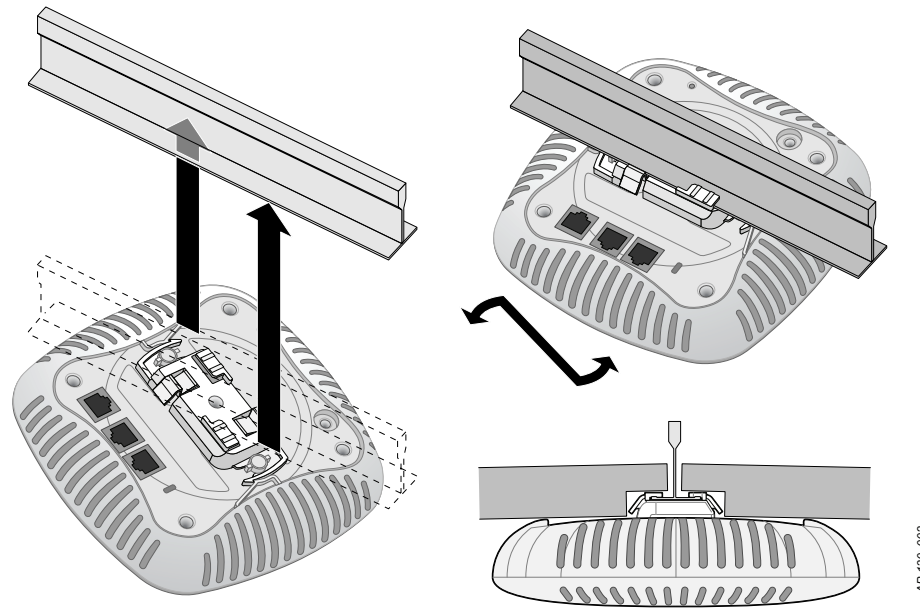

7. On the W-API34, install the external antennas according to the manufacturer's instructions, and connect the antennas to the antenna interfaces on the AP.

Connecting Required Cables

Install cables in accordance with all applicable local and national regulations and practices.

Ethernet Ports

The RJ45 Ethernet ports (ENET0 and ENET1) support 10/100/1000Base-T auto-sensing MDI/MDX connections. Use these ports to connect the AP to a twisted pair Ethernet LAN segment or directly to a Dell Controller. Use a 4- or 8-conductor, Category 5 UTP cable up to 100 m (325 feet) long.

The 10/100/1000 Mbps Ethernet ports are on the bottom of the AP. These ports have RJ-45 female connectors with the pin-outs shown in [Table 1](#).

Table 1 Ethernet Port Pin-out

Connector	Pin	Signal Name	GE Connection	FE Connection	PoE
	1	BI_DA+	Bi-directional pair A+	RX+	POE negative
	2	BI_DA-	Bi-directional pair A-	RX-	POE negative
	3	BI_DB+	Bi-directional pair B+	TX+	POE positive
	4	BI_DC+	Bi-directional pair C+	Spare pair	POE positive
	5	BI_DC-	Bi-directional pair C-	Spare pair	POE positive
	6	BI_DB-	Bi-directional pair B-	TX-	POE positive
	7	BI_DD+	Bi-directional pair D+	Spare pair	POE negative
	8	BI_DD-	Bi-directional pair D-	Spare pair	POE negative

Serial Console Port

The serial console port allows you to connect the AP to a serial terminal or a laptop for direct local management. This port is an RJ-45 female connector with the pinouts described in [Table 2](#). Connect this port in one of the following ways:

- Connect it directly to a terminal or terminal server using an Ethernet cable.
- Use a modular adapter to convert the RJ-45 (female) connector on the AP to a DB-9 (male) connector, and connect the adapter to a laptop using an RS-232 cable. [Figure 5](#) illustrates the connector details of the adapter.

Table 2 Console Port Pin-out

Connector	Pin	Signal Name	Function
	3	TXD	Transmit
	4	GND	Ground
	5	GND	Ground
	6	RXD	Receive
	Pins not listed are not connected.		

Figure 5 RJ-45 (Female) to DB-9 (Male) Modular Adapter Conversion



Power Connection

The W-AP130 Series has a single 12V DC power jack socket to support powering through an AC-to-DC power adapter.

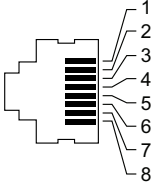
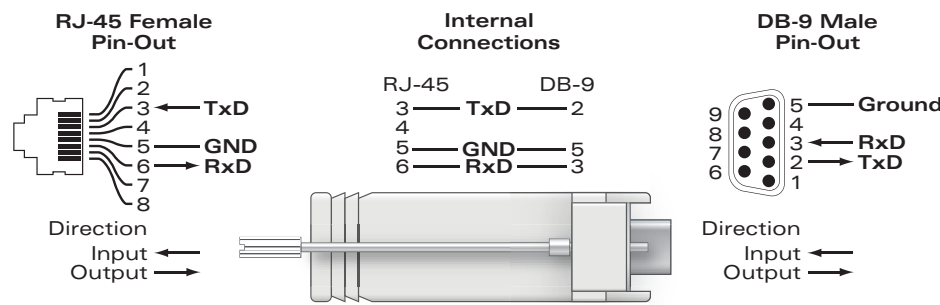

NOTE: If both POE and DC power are available, the AP uses POE even when there is not enough POE voltage available to power the AP.

Verifying Post-Installation Connectivity

The integrated LEDs on the AP can be used at this point to verify that the AP is receiving power and initializing successfully (see [Table 3](#)). Refer to the *Dell PowerConnect W-Series ArubaOS 6.1 Quick Start Guide* for further details on verifying post-installation network connectivity.

Table 3 W-AP130 Series LED Behavior

LED	Color/State	Meaning
PWR	Off	No power to AP
	Green steady	Power on, device ready
	Green flashing	Device booting, not ready
	Red steady	System failed to initialize
ENET 0 (100/1000 Mbps)	Green/Amber off	No link
	Green on	1000 Mbps link
	Amber on	10/100 Mbps link
	Green/amber blinking	Link activity
ENET 1 (100/1000 Mbps)	Green/Amber off	No Link
	Green on	1000 Mbps link
	Amber on	10/100 Mbps link
	Green/amber blinking	Link activity
11A/N	Off	5 GHz radio disabled
	Amber	5 GHz radio enabled in 11a mode
	Green steady	5 GHz radio enabled in 11n mode
	Green flashing	5 GHz Air Monitor mode
11B/G/N	Off	2.4 GHz radio disabled
	Amber	2.4 GHz radio enabled in 11b/g mode
	Green steady	2.4 GHz radio enabled in 11n mode
	Green flashing	2.4 GHz Air Monitor Mode

Configuring the W-AP130 Series

AP Provisioning/Reprovisioning

Provisioning parameters are unique to each AP. These local AP parameters are initially configured on the Controller which are then pushed out to the AP and stored on the AP itself. Dell recommends that provisioning settings be configured via the ArubaOS WebUI only. Refer to the *Dell PowerConnect W-Series ArubaOS 6.1 User Guide* for complete details.

AP Configuration

Configuration parameters are network or controller specific and are configured and stored on the Controller. Network configuration settings are pushed out to the AP(s) but remain stored on the Controller.

Product Specifications

Mechanical

- Dimensions (antenna stowed) (HxWxD):
 - 6.69 inches x 6.69 inches x 1.77 inches
 - 17.0 cm x 17.0 cm x 4.5 cm
- Weight: 1.68 lbs/760 g
- Shipping Dimensions:
 - 11.22 inches x 9.45 inches x 2.76 inches
 - 28.5 cm x 24.0 cm x 7.0 cm
- Temperature:
 - Operating: 0°C to 50°C (32°F to 122°F)



NOTE: Operating temperature range is reduced to **0°C to 40°C (32°F to 104°F)** when this AP is used in conjunction with the Sunny SYS1357-1812 power adapter.

- Storage: -40°C to 70°C (-40°F to 158°F)
- Relative Humidity: 5% to 95% non-condensing
- Mounting:
 - Ceiling (with included adapter)
 - Wall (with adapter, sold separately)
- Antennas:
 - 6 integrated antenna elements (W-AP135)
 - 3 RP-SMA interfaces for external antennas (W-AP134)
- Visual Status Indicators (LEDs): See [Table 3](#)

Electrical

- Ethernet:
 - 2 x 10/100/1000 Base-T auto-sensing Ethernet RJ-45 Interfaces
 - MDI/MDX
 - IEEE 802.3 (10Base-T), IEEE 802.3u (100Base-T), IEEE 802.3ab (1000Base-T)
 - Power over Ethernet (IEEE 802.3at compliant), 48V DC/350mA (see [Table 1 on page 7](#) for pin configuration)
- Power:
 - 12 VDC power interface, supports powering through an AC-to-DC mains electric power adapter



NOTE: If a power adapter other than the one provided by Dell is used in the US or Canada, it should be cULus (NRTL) Listed, with an output rated 12VDC, minimum 1.25A, marked "LPS" or "Class 2," and suitable for plugging into a standard power receptacle in the US and Canada. For information on approved power adapters, see support.dell.com

- POE support on Ethernet ports:
 - 802.3at-compliant POE sourcing devices

Wireless LAN

- Network Standards: IEEE 802.11b, IEEE 802.11g, IEEE 802.11a, and IEEE 802.11n
- Antenna Type:
 - Integrated 802.11a/b/g/n omni-directional high-gain antenna
 - Detachable 802.11a/b/g/n omni-directional high-gain antenna
- Antenna Gain (Integrated Antennas):
 - 2.4 – 2.5 GHz (max)
 - 5.180 – 5.825 GHz (max)
- Radio Technology:
 - Orthogonal Frequency Division Multiplexing (OFDM)
 - Direct Sequence Spread Spectrum (DSSS)
 - 3 x 3 MIMO with up to three spatial streams
- Radio Modulation Type:
 - 802.11b - CCK, BPSK, QPSK
 - 802.11a/g/n - CCK, BPSK, QPSK, 16-QAM, 64-QAM
- Media Access Control: CSMA/CA with ACK
- Supported Frequency Bands 2.4GHz:
 - 2.400 ~ 2.4835GHz (Global), channels country specific
- Supported Frequency Bands 5GHz:
 - 5.150 ~ 5.250GHz (low band), country-specific
 - 5.250 ~ 5.350GHz (mid band), country-specific
 - 5.470 ~ 5.725GHz (Europe), country-specific
 - 5.725 ~ 5.850GHz (high band), country-specific
- Data Rates:
 - 802.11b - 1, 2, 5.5, 11 Mbps per channel
 - 802.11g - 6, 9, 12, 18, 24, 36, 48 and 54 Mbps per channel
 - 802.11a - 6, 9, 12, 18, 24, 36, 48 and 54 Mbps per channel
 - 802.11n - Data rate MCS0 – MCS23 (from 6.5 Mbps to 450 Mbps)

Proper Disposal of Dell Equipment

For the most current information about Global Environmental Compliance and Dell products, see www.dell.com.

Waste of Electrical and Electronic Equipment

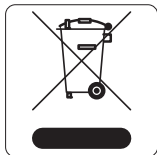

Dell products at end of life are subject to separate collection and treatment in the EU Member States, Norway, and Switzerland and therefore are marked with the symbol shown at the left (crossed-out wheeled bin). The treatment applied at end of life of these products in these countries shall comply with the applicable national laws of countries implementing Directive 2002/96EC on Waste of Electrical and Electronic Equipment (WEEE).

European Union RoHS



Dell products also comply with the EU Restriction of Hazardous Substances Directive 2002/95/EC (RoHS). EU RoHS restricts the use of specific hazardous materials in the manufacture of electrical and electronic equipment. Specifically, restricted materials under the RoHS Directive are Lead (including Solder used in printed circuit assemblies), Cadmium, Mercury, Hexavalent Chromium, and Bromine. Some Dell products are subject to the exemptions listed in RoHS Directive Annex 7 (Lead in solder used in printed circuit assemblies). Products and packaging will be marked with the “RoHS” label shown at the left indicating conformance to this Directive.

China RoHS



Dell products also comply with China environmental declaration requirements and are labeled with the “EFUP 10” label shown at the left.

有毒有害物质声明 Hazardous Materials Declaration

部件名称 (Parts)	有毒有害物质或元素 (Hazardous Substance)					
	铅 (Pb)	汞 (Hg)	镉 (Cd)	六价铬 (Cr ⁶⁺)	多溴联苯 (PBB)	多溴二苯醚 (PBDE)
电路板 (PCA Boards)	×	○	○	○	○	○
机械组件 (Mechanical Sub-Assemblies)	×	○	○	○	○	○

○：表示该有毒有害物质在该部件所有均质材料中的含量均在 SJ/T11363-2006 标准规定的限量要求以下。
Indicates that the concentration of the hazardous substance in all homogeneous materials in the parts is below the relevant threshold of the SJ/T11363-2006 standard.

×：表示该有毒有害物质至少在该部件的某一均质材料中的含量超出 SJ/T11363-2006 标准规定的限量要求。
Indicates that the concentration of the hazardous substance of at least one of all homogeneous materials in the parts is above the relevant threshold of the SJ/T11363-2006 standard.

对销售之目的所售产品，本表显示，供应链的电子产品信息产品可能包含这些物质。
This table shows where these substances may be found in the supply chain of electronic information products, as of the date of sale of the enclosed product.

此标志为针对所涉及产品的环保使用期标志。某些零部件会有一个不同的环保使用期 (例如，电池单元模块) 贴在其产品上。
此环保使用期限只适用于产品是在产品手册中所规定的条件下工作。
The Environment-Friendly Use Period (EFUP) for all enclosed products and their parts are per the symbol shown here. The Environment-Friendly Use Period is valid only when the product is operated under the conditions defined in the product manual.

Safety and Regulatory Compliance

Dell provides a multi-language document containing country specific restrictions and additional safety and regulatory information for all Dell hardware products. The *Dell PowerConnect W-Series Safety, Environmental, and Regulatory Information* document is included with this product.

FCC Class B Part 15

This device complies with Part 15 of the Federal Communications Commission (FCC) Rules. Operation is subject to the following two conditions:

- This device may not cause harmful interference.
- This device must accept any interference received, including interference that may cause undesired operation.



CAUTION: Changes or modifications to this unit not expressly approved by the party responsible for compliance could void the user's authority to operate this equipment.

This equipment has been tested and found to comply with the limits for a Class B digital device, pursuant to Part 15 of the FCC Rules. This equipment generates, uses and can radiate radio frequency energy and, if not installed and used in accordance with the manufacturer's instructions, may cause interference harmful to radio communications.

If this equipment does cause interference, which can be determined by turning the equipment off and on, the user is encouraged to try to correct the interference by one or more of the following measures:

- Reorient or relocate the receiving antenna.
- Increase the separation between the equipment and receiver.
- Connect the equipment to an outlet on a circuit different from that to which the receiver is connected.
- Consult the dealer or an experienced radio or TV technician for help.

Complies with the Class B limits for radio noise emissions as set out in the interference-causing equipment standard entitled “Digital Apparatus,” ICES-003 of Industry Canada.

Cet appareil numérique de la classe B respecte toutes les exigences du Règlement sur le matériel brouilleur du Canada.

EU Regulatory Conformance

This product is CE marked according to the provisions of the R & TTE Directive (99/5/EC) - CE 2280(!). Dell, hereby declares that this W-API34 and W-API35 device models are in compliance with the essential requirements and other relevant provisions of Directive 1999/5/EC. CE 2280(!)

The Declaration of Conformity made under Directive 1999/5/EC is available for viewing at the following location in the EU community.



CAUTION: RF Radiation Exposure Statement: This equipment complies with FCC RF radiation exposure limits. This equipment should be installed and operated with a minimum distance of 13.78 inches (35 cm) between the radiator and your body for 2.4 GHz and 5 GHz operations. This transmitter must not be co-located or operating in conjunction with any other antenna or transmitter. When operated in the 5.15 to 5.25 GHz frequency range, this device is restricted to indoor use to reduce the potential for harmful interference with co-channel Mobile Satellite Systems.

GS Statement

This device is not intended for use in the direct field of view at visual display workplaces. To avoid incommoding reflexions at visual display workplaces, this device must not be placed in the direct field of view.

This page is intentionally left blank

This page is intentionally left blank

Contacting Support

Website Support	
Main Website	dell.com
Support Website	support.dell.com
Dell Documentation	support.dell.com/manuals

Copyright

© 2011 Aruba Networks, Inc. Aruba Networks trademarks include  **airwave**, Aruba Networks®, Aruba Wireless Networks®, the registered Aruba the Mobile Edge Company logo, and Aruba Mobility Management System®. Dell™, the DELL™ logo, and PowerConnect™ are trademarks of Dell Inc.

All rights reserved. Specifications in this manual are subject to change without notice.

Originated in the USA. All other trademarks are the property of their respective owners.

Open Source Code

Certain Aruba products include Open Source software code developed by third parties, including software code subject to the GNU General Public License (GPL), GNU Lesser General Public License (LGPL), or other Open Source Licenses. The Open Source code used can be found at this site:

http://www.arubanetworks.com/open_source

Legal Notice

The use of Aruba Networks, Inc. switching platforms and software, by all individuals or corporations, to terminate other vendors' VPN client devices constitutes complete acceptance of liability by that individual or corporation for this action and indemnifies, in full, Aruba Networks, Inc. from any and all legal actions that might be taken against it with respect to infringement of copyright on behalf of those vendors.